



Ball Valve Locking Device Kit Installation Instructions

These instructions apply to the following SSP BALL VALVES



- EB Series 41, 42, and 43

Compact Kit Contents

Installation Instructions	
Locking Device	

The locking device can be used to lock the valve in the open or closed position by placing a padlock through the shackle hole in the locking device. The locking device is designed for use with padlock shackle diameters from 3/16 to 9/32 (4.8 to 7.1 mm).

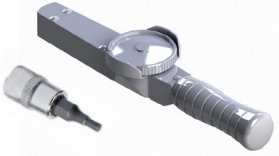
Suggested Tools

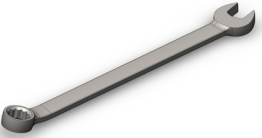
Torque wrench with hex adapter (see chart)	Or	Hex key (see chart)	Torque wrench with crows-foot adapter (see chart)	Or	Open-end wrench (see chart)
					

Valve Preparation

Note direction of handle prior to removal. Handle must be reinstalled pointing in the same direction. Loosen set screw to remove handle and panel nut.

WARNING
before removing a valve from the system for service, you must

- Depressurize System
- Cycle The Valve

WARNING
Residual system media may be left in the valve.

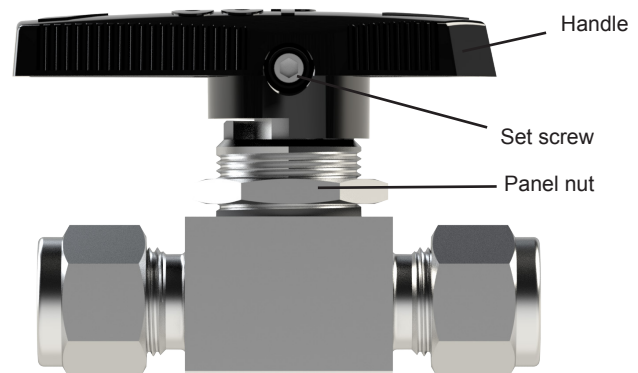

Installation

Refer to Figure 1 during installation.

1. Place locking plate over valve bonnet as shown.
2. Rotate locking device until protrusions on bottom of the locking device engage with valve body (The shackle hole must be on the handle stop side). Thread on panel nut and tighten to torque value listed in chart.
3. Install handle and tighten setscrew to torque value listed in chart.

Valve Size	Panel Nut	Handle Set Screw	Panel Nut	Handle Set Screw
	Open-End Extension	Hex Wrench	Torque in.·lb (N·m)	Torque in.·lb (N·m)
EB41G, EB42G	3/4 in.	5/64 in.	50 (5.7)	30 to 35 (3.4 to 4.0)
EB43G	1 in.	3/32 in.	150 (17.0)	30 to 35 (3.4 to 4.0)



WARNING
The locking device must be flush against the valve body.

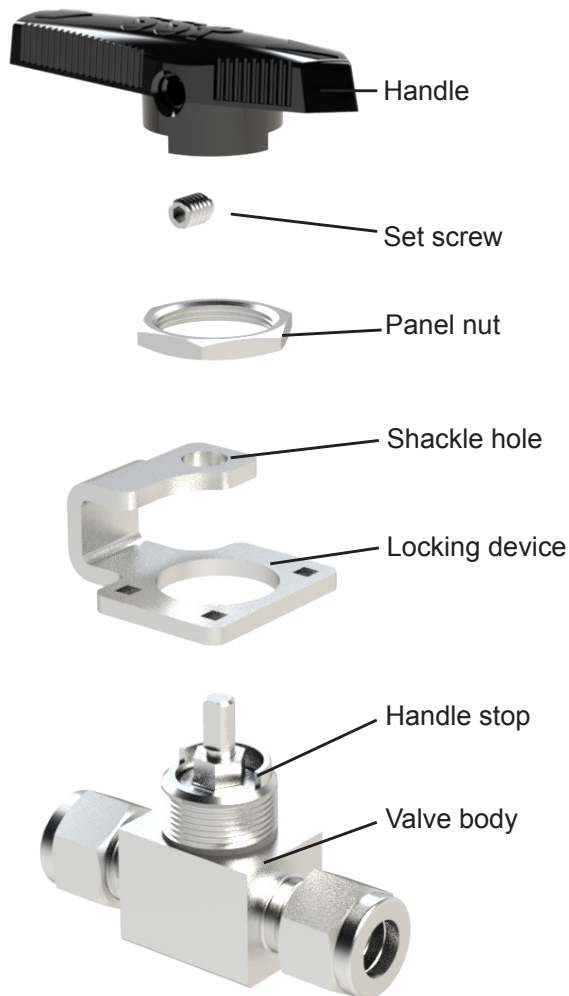

Figure 1

