



Ball Valve Locking Device Kit Installation Instructions

These instructions apply to the following SSP BALL VALVES

- EB Series (all)
- FB Series (all)
- TB Series (all)

Standard Kit Contents

Installation Instructions

Locking Device Assembly



Suggested Tools

Torque wrench with hex adapter (see chart)	Or	Hex key (see chart)	Torque wrench with crow's-foot adapter (see chart)	Or	Open-end wrench (see chart)

Valve Preparation

Note direction of handle prior to removal. Handle must be reinstalled pointing in the same direction. Loosen set screw to remove handle and panel nut.

WARNING
before removing a valve from the system for service, you must

- Depressurize System
- Cycle The Valve

WARNING
Residual system media may be left in the valve.

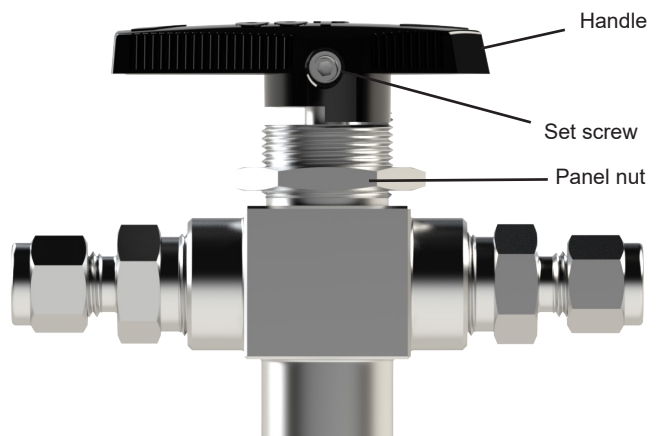

Installation

Refer to Figure 1 during installation.

1. Place locking plate over valve bonnet as shown.
2. Rotate locking plate until protrusions on bottom of the locking plate engage with valve body (The locking arm must be opposite of the handle stop). Thread on panel nut and tighten to torque value listed in chart.
3. Install handle and tighten setscrew to torque value listed in chart.

Valve Size	Panel Nut	Handle Set Screw	Panel Nut	Handle Set Screw
	Open-End Extension	Hex Wrench	Torque in.·lb (N·m)	Torque in.·lb (N·m)
EB43G	1 in.	3/32 in.	150 (17.0)	30 to 35 (3.4 to 4.0)
EB44G	1 1/4 in.	1/8 in.	250 (28.2)	30 to 35 (3.4 to 4.0)
EB45G	1 5/8 in.	5/32 in.	400 (45.2)	130 to 135 (14.7 to 15.3)
FB36	1 in.	3/32 in.	150 (17.0)	30 to 35 (3.4 to 4.0)
FB38	1 5/8 in.	5/32 in.	400 (45.2)	130 to 135 (14.7 to 15.3)
TB83	1 1/8 in.	3/32 in.	100 (11.3)	10 to 15 (1.1 to 1.7)

WARNING
 The locking plate must be flush against the valve body.

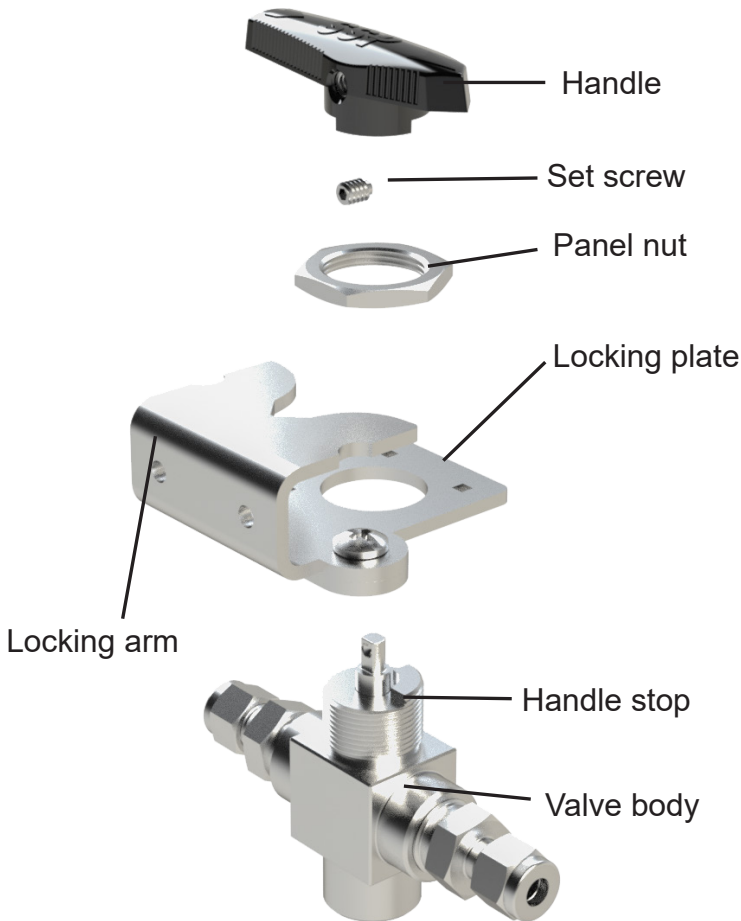
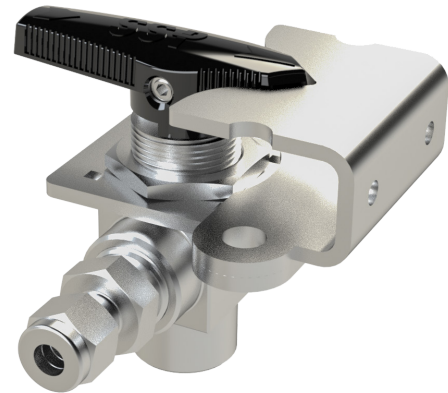

Figure 1

Open



Closed

